	<b>ITTC – Recommended Procedures</b>	<b>7.6-02-05</b> Page 1 of 11	
	<b>Sample Work Instructions Calibration of Dial Gauges</b>	Effective Date 2002	Revision 00

## CONTENTS

### PURPOSE

### WORK INSTRUCTION

- 1. Introduction**
- 2. Item and condition of calibration**
  - 2.1 Items and Main Tools of Calibration
  - 2.2 Calibration Conditions
- 3. Technical requirements and calibration method**
  - 3.1 Exterior
  - 3.2 Relationship Among Parts
  - 3.3 Relative positions of point hand and dial plate
  - 3.4 Width of Indicator Needle End and Dial Plate Lines
  - 3.5 Roughness of Measuring Head Working Surface
  - 3.6 Diameter of clamping sleeve
  - 3.7 Measuring force
  - 3.8 Hysteresis of Indication
  - 3.9 Effect on indication from radial force of survey rod
  - 3.10 Error of indication
  - 3.11 Error of Return
- 4 Treatment of calibration result and calibration period**
  - 4.1 Treatment of Calibration Result
  - 4.2 Calibration Period

### APPENDIX

#### Calibration method for additional points

#### Source

**Verification regulation of dial gauge (reading in 0.01 mm and 0.001 mm)**

[Issued on Feb. 14, 1996 and put into effect since June 1, 1996 by National Technical Bureau - **JJG 34—96, National Measuring Verification Regulation of People’s Republic of China**]

Edited	Approved
Quality Systems Group of 23 <sup>rd</sup> ITTC	23 <sup>rd</sup> ITTC 2002
Date	Date

## Calibration of Dial Gauges

### PURPOSE

This working instruction can be applied to the verification of new dial gauges or to the calibration of dial gauges in service and after repair, having a scale division of 0.01 mm, measuring ranges 0~3、0~5、0~10 mm and with a scale division of 0.001 mm and measuring ranges between 0~1、0~2、0~3、0~5mm.

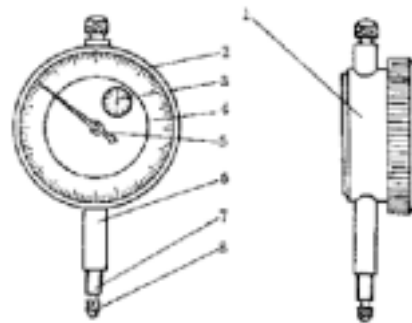

Fig. 1 Dial gauge (with the reading in 0.01mm)

Where, 1 dial gauge body; 2 dial gauge ring; 3 revolution point hand; 4 dial plate; 5 point hand (needle); 6 clamping sleeve; 7 survey rod; 8 measuring head.

### WORK INSTRUCTION

#### 1. Introduction

Dial gauge is a metrological tool which uses the rack gear or the level gear operation to transfer the line displacement of the survey rod into an angular one of the pointer hand. Its main usage is to measure the size、the shape and the position error of products. The outlines of the dial gauges are shown in Figure 1 (reading in 0.01mm) and in Figure 2 (reading in 0.001mm).

#### 2. Item and condition of calibration

##### 2.1 Items and Main Tools of Calibration

The items and the main tools of the calibration for dial gauges are listed in Table 1.

##### 2.2 Calibration Conditions

Before the calibration the dial gauge must be kept in the room for temperature equilibrium and by the time of the calibration the room temperature must meet the requirements in Table 2.

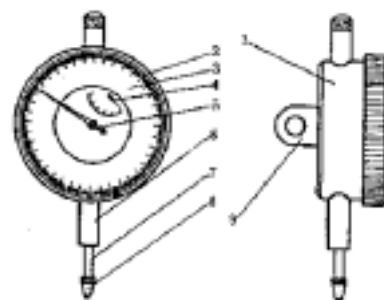

Fig.2 Dial gauge (with the reading in 0.001mm)

Where, 1 dial gauge body; 2 dial gauge ring; 3 dial plate; 4 revolution point hand; 5 point hand; 6 clamping sleeve; 7 survey rod; 8 measuring head; 9 ear ring.

	<b>ITTC – Recommended Procedures</b>	<b>7.6-02-05</b> Page 3 of 11	
	<b>Sample Work Instructions</b> <b>Calibration of Dial Gauges</b>	Effective Date 2002	Revision 00

Table 1

No	Item	Main calibration tools	Type of calibration		
			New product	In service	After repair
1	Exterior	-----	+	+	+
2	Relationship among parts	Raster calibration instrument for dial gauge or dial gauge calibrator	+	+	+
3	Relative positions of pointer hand and dial plate	Tool microscope	+	+	+
4	Width of pointer hand end and dial plate lines	Tool microscope	+	-	+
5	Roughness of measuring head working surface	Sample block for comparison of surface roughness or measuring apparatus of surface roughness	+	-	+
6	Diameter of clamping sleeve	First class	+	-	+
7	Measuring force	Force gauge	+	+	+
8	Hysteresis of indication	Rigid mounting for dial gauge, leveling working platform	+	+	+
9	Effect on indication from radial force of survey rod	Half cylinder side block, rigid mounting for dial gauge, working platform with reinforcement	+	+	+
10	Error of indication	Raster calibration instrument for dial gauge or dial gauge calibrator	+	+	+
11	Error of return		+	+	+

Note: “+” means calibration must be done; “-“ means calibration may not be done

### 3. Technical requirements and calibration method

#### 3.1 Exterior

Requirement: The watch glass of the dial gauge should be transparent and clear without any air bubbles and obvious scores.

Table 2

Room temperature	Temperature Change per hour	Time for Temperature balance
$20 \pm 10$ °C	$\nless 1$ °C	$\geq 2$ h

	<b>ITTC – Recommended Procedures</b>	<b>7.6-02-05</b> Page 4 of 11	
	<b>Sample Work Instructions</b> <b>Calibration of Dial Gauges</b>	Effective Date 2002	Revision 00

3.1.1 The lines of the dial plate should appear clear and straight to the eye, without any breaks and uneven thickness. The measuring head should not have any mechanical damage, rust spots or obvious scoring. There should be no paint drops, poor chromium plating, burrs or any other fault which affects the exterior quality. The name of the manufacturer or the trademark, the scale division value and the production serial number should be marked on the dial gauge. A dial gauge in service and after repair should not have an exterior fault which affects its accuracy.

3.1.2 Calibration method: By eyesight.

### 3.2 Relationship Among Parts

#### 3.2.1 Requirements

3.2.1.1 The dial gauge ring should be steadily movable. Its stopping should be reliable. The clearance between ring and body should not have obvious looseness.

3.2.1.2 The movement of the survey rod and the return of the needle should be steady and nimble without any phenomena like jumping, seizure, and retarded motion.

3.2.1.3 The pointer hand should be tightly fixed on the shaft. It should not be loose when the survey rod is moved.

3.2.1.4 The survey rod should be freely movable and must not be seized after the clamping sleeve has been positioned and fastened on the dial gauge.

3.2.2 Calibration method: Testing and observation.

### 3.3 Relative positions of point hand and dial plate

#### 3.3.1 Requirements

3.3.1.1 The zero line of the dial plate should be adjusted till it coincidences with the shaft direction of the survey rod, when the survey rod of the dial gauge locates at the free position. This position of the needle should meet the requirement in Table 3

Table 3 (scale division)

Scale mark type of dial plate	Pointer hand locates on upper-left of zero scale mark
50	4~12
100	8~25
200	16~50

3.3.1.2 The survey rod running distance of the dial gauge should exceed the end point of the working running distance. The exceeding running distance should meet the requirement written in Table 4.

Table 4

Type	Measuring range (mm)	Scale mark type of dial plate (scale division)	Running distance beyond end point (mm)
Reading in 0.01mm	0~3	50	$\geq 0.30$
	0~5, 0~10	100	$\geq 0.50$
Reading in 0.001mm	0~1, 0~2, 0~3	100	$\geq 0.05$
	0~5	200	$\geq 0.10$

	<b>ITTC – Recommended Procedures</b>	<b>7.6-02-05</b> Page 5 of 11	
	<b>Sample Work Instructions Calibration of Dial Gauges</b>	Effective Date 2002	Revision 00

3.3.1.3 When the revolving needle points to any of the integral revolutions the position of the needle should meet the requirements in Table 5.

Table 5 (scale division)

Type	Point hand deviation from the zero position
Reading in 0.01mm	$\leq 15$
Reading in 0.001mm	$\leq 20$

3.3.1.4 The direction of the needle end should be the same as the one of the dial plate line, without any deflection seen by eyesight. The distance between the upper surface of the needle end and the dial plate shouldn't exceed the values in Table 6.

3.3.1.5 The end of the needle should cover 30~80% length of the short scale mark.

### 3.3.1 Calibration Method:

The distance between the upper surface of the needle end and the dial plate can be observed by eyesight. If there is any dispute, it can be calibrated by use of a tool microscope with the lens at five-times magnification. The lens can be focused on the upper surface of the needle and the dial plate respectively, the values can be ob-

tained by reading with the final motion device or can be read through an additional dial gauge with an accuracy of 0.0 1mm. The difference of these two readings is the distance between the upper surface of the needle end and the plane of the dial plate.

Table 6

Type	Scale mark type of dial plate (scale division)	Distance between pointer hand end upper surface and dial plate
Reading in 0.01mm	50, 100	0.9mm
	100	0.9mm
	200	0.7mm

### 3.4 Width of Indicator Needle End and Dial Plate Lines

3.4.1 Requirements: The values in Table 7 should not be exceeded.

3.4.2 Calibration method

The calibration can be made by use of a tool microscope. At least three lines should be selectively calibrated.

Table 7

Type	Measured range (mm)	Scale mark type of dial plate (scale division)	Diameter of dial gauge ring	Width of pointer hand end and dial plate lines (mm)
Reading in 0.01mm	0~3	50	42mm	0.10~0.20
	0~5, 0~10	100	>42mm	0.15~0.25
Reading in 0.001mm	0~1, 0~2, 0~3, 0~5	100	42mm	0.10~0.20
			>42mm	0.15~0.25
	200	>42mm	0.10~0.20	



# ITTC – Recommended Procedures

7.6-02-05  
Page 6 of 11

## Sample Work Instructions Calibration of Dial Gauges

Effective Date  
2002

Revision  
00

### 3.5 Roughness of Measuring Head Working Surface

3.5.1 Requirements: The values in Table 8 should not be exceeded.

Table 8 (μ m)

Material of measuring head	Steel	Hard alloy	Gem
Roughness of measuring head working surface	$R_a$ 0.1	$R_a$ 0.2	$R_a$ 0.05

3.5.2 Calibration method: It may be calibrated using the comparing method with a sample block for the comparison of the surface roughness. If there is any dispute, a measuring

apparatus of surface roughness can be used for calibration.

### 3.6 Diameter of clamping sleeve

3.6.1 Requirement: The diameter should be  $\phi 8_{-0.015}^{+0}$  mm.

3.6.2 Calibration method: The calibration of the clamping sleeve diameter can be made by use of a first class dial gauge.

### 3.7 Measuring force

3.7.1 Requirement: The measuring force should not exceed the values in Table 9.

Table 9 (N)

Type	Measured range (mm)	Maximum measured force	Change of measured force in one direction running distance	Change of measured force in go and return direction at same point
Reading in 0.01mm	0~3, 0~5, 0~10	1.5	0.5	0.4
Reading in 0.001mm	0~1, 0~2	1.5	0.4	0.4
	0~3, 0~5	1.5	0.5	0.5

3.7.2 Calibration Method: The calibration should be carried out at three positions, the beginning, the mid and the end position of the working running distance for the dial gauge using a force gauge with the scale division not bigger than 0.1 N. After the forward direction calibration is over, let the needle continue going for 5~10 scale divisions, then the return direction calibration can be carried out.

The maximum force measured in the forward running direction is taken as the

maximum measured force of the dial gauge. The difference of the maximum and the minimum forces measured in one direction are taken as the change of the measured force in one direction. The difference between the measured forces in the forward and the return direction, at the calibration points, can be taken as the change of the measured force in forward and return directions at the same point. All of these should not exceed the values in Table 9.

	<b>ITTC – Recommended Procedures</b>	<b>7.6-02-05</b> Page 7 of 11	
	<b>Sample Work Instructions Calibration of Dial Gauges</b>	Effective Date 2002	Revision 00

Table 10 ( $\mu\text{m}$ )

Type	Measurement range (mm)	Indication hysteresis		Effect on indication from radial force of survey rod	
		Zero class	First class	Zero class	First class
Reading in 0.01mm	0~3, 0~5, 0~10	3	5	3	5
Reading in 0.001mm	0~1, 0~2, 0~3	0.3	0.5	0.3	0.5
	0~5	0.4	0.5	0.4	0.5

### 3.8 Hysteresis of Indication

3.8.1 Requirement: The hysteresis of indication for the dial gauge should not exceed the values in Table 10.

3.8.2 Calibration Method: The dial gauge should be clamped on a rigid mounting to make the shaft line of the survey rod vertical to the leveling plane. The survey rod must be lifted five times when the needle has been adjusted until it points to the scale mark at the beginning, the mid and the end positions of the range respectively. The difference between the maximum and the minimum values of five readings each are taken as the indication hysteresis of the relevant point. The indication hystereses at the above mentioned three positions should not exceed the values in Table 10.

### 3.9 Effect on indication from radial force of survey rod

3.9.1 Requirement: The values in Table 10 shouldn't be exceeded.

3.9.2 Calibration Method: The dial gauge should be clamped on a rigid mounting to make the shaft line of the survey rod vertical to the working platform with rein-

forcement. One piece of the half cylinder side block with a radius of 10 mm (appendage of the measuring block) should be positioned between the measuring head and the working platform. The dial gauge at the zero position of the working range should be adjusted till the point near the maximum position of the side block cylinder surface is touched. The side block should be moved twice for each of four positions, the front, the back, the left and the right of the gauge along the direction vertical to the generating line of the side block respectively. The maximum value (the turning point) should be read each time when the measuring head touches the maximum point of the side block. The difference of the maximum and the minimum among eight readings should not exceed the values in Table 10. Such a calibration should be performed at the middle and the end positions of the measurement range.

### 3.10 Error of indication

3.10.1 Requirements: The indication errors of 0.01 and 0.001mm reading dial gauges should not exceed the values in Tables 11 and 12 respectively.



# ITTC – Recommended Procedures

**7.6-02-05**  
Page 8 of 11

## Sample Work Instructions Calibration of Dial Gauges

Effective Date  
2002

Revision  
00

### 3.10.2 Calibration Method

3.10.2.1 Dial gauges with in 0.01 mm readings can be calibrated by use of a raster calibration instrument for dial gauges or a calibrator for dial gauges with 0.01mm readings. Dial gauges with 0.001 mm readings can be calibrated by use of a raster calibration instrument for dial gauges or a calibrator dial gauges with 0.001 mm readings. Other methods can be used for the calibration, the accuracy of which should not be lower.

3.10.2.2 The zero positioning of the calibration instrument (or the calibrator) and of the dial gauge should be adjusted at the beginning of the calibration. The indication error of the dial gauge with a 0.01 mm reading should be calibrated at the points of every 10-scale division interval in the direction of the forward and the return travel The indication error of dial gauges with a 0.001 mm reading should be cali-

brated at the points of every 50-scale division interval in the direction of the forward and the return travel The relevant error of every point can be read from the dial gauge after the needle has been shifted to the scale divisions of the instrument, till the end of the working running distance. Then the survey rod can be compressed for the needle turning 10-scale division and the calibration can be carried out in the return direction.

During the whole calibration process the direction of travel of the survey rod must not be changed right in the middle and any adjustment must not be done on the calibrated dial gauge and on the calibrating instrument (or the calibrator). Whether the error in the return travels positive or negative can be determined in the same way as that for the forward travel running distance.

Table 11

Accuracy class	Indication error of 0.01mm reading dial gauge ( $\mu$ m)					Return error ( $\mu$ m)
	Optional 0.1mm	Optional 1mm	Working running distance			
			0~3mm	0~5mm	0~10mm	
0	5	8	10	12	14	3
1	7	10	15	18	20	5

Table 12

Measured range (mm)	Indication error of 0.001mm reading dial gauge ( $\mu$ m)				Return error ( $\mu$ m)	
	Optional 0.2mm		Working running distance		Zero class	First class
	Zero class	First class	Zero class	First class		
0~1	3.0	3.5	4	5	2.0	2.5
0~2	3.0	3.5	5	6	2.0	2.5
0~3	3.5	4.0	7	8	2.5	3.0
0~5	3.5	4.0	8	9	2.5	3.0

	<b>ITTC – Recommended Procedures</b>	<b>7.6-02-05</b> Page 9 of 11	
	<b>Sample Work Instructions Calibration of Dial Gauges</b>	Effective Date 2002	Revision 00

- 3.10.2.1 The indication error of the measuring range of the dial gauge can be determined from the difference of the maximum and the minimum values of the errors at each calibrated point within the measuring range.
- 3.10.2.2 The indication error of a dial gauge with a reading in 0.01 mm at the condition of optional 1 mm can be determined from the difference between the maximum and the minimum of the errors measured in each section of the forward travel 0~1、1~2、2~3、3~4、 mm.  
The indication error of a dial gauge with 0.001 mm readings at the condition of optional 0.2 mm can be determined from the difference between the maximum and the minimum of the errors measured in each section of the direction of forward travel 0~0.2、 0.2~0.4、 0.4~0.6、 mm.
- 3.10.2.3 The indication error of the dial gauge with 0.01 mm readings within the range of optional 0.1 mm can be determined from the difference of the errors measured at two optional adjacent points in the direction of forward travel.
- 3.10.2.4 The calibration of the indication error for an in service dial gauge with 0.01 mm readings by use of the 0.01 mm reading dial gauge calibrator can be carried out on the basis of 20-scale division interval. After this calibration is over, if the indication errors of the working running distance and the optional 1mm are close to the values in Table 11 and the indication error of the adjacent points exceeds the values of the optional 0.1mm indication error in Table 11, calibration of additional points should be carried out. This method is shown in the Appendix.

### 3.11 Error of Return

- 3.11.1 Requirement: The return error of the dial gauge should not exceed the values given in Tables 11 and 12.
- 3.11.2 Calibration method: After the calibration of the indication error, the maximum of the differences of the errors between the forward and the return directions of travel can be taken as return error at the same point .  
Table 13 shows the data treatment of the indication and the return errors of the dial gauge with the reading in 0.01 mm.  
The indication error of the measuring range :  $10 - (-3) = 13 \mu m$   
The indication error within the range of the optional 0.1mm:  $4 - (-1) = 5 \mu m$   
The indication error within the range of the optional 1mm: the indication error within the range of 2~3 mm is at maximum.  
 $10 - (-1) = 11 \mu m$   
The return error:  $2 - (-1) = 3 \mu m$

## 4 **Treatment of calibration result and calibration period**

### 4.1 Treatment of Calibration Result

For the dial gauges that meet the requirements of this working instruction during calibration, a calibration report will be supplied; For the ones which do not meet the requirements a notice of the calibration result will be supplied.

### 4.2 Calibration Period

The calibration period can be determined upon the service condition, but not longer than one-year.

	<b>ITTC – Recommended Procedures</b>		<b>7.6-02-05</b> Page 10 of 11	
	<b>Sample Work Instructions</b> <b>Calibration of Dial Gauges</b>		Effective Date 2002	Revision 00

Table 13

Distance of travel(mm)		Calibrated point (scale division)										
		0	10	20	30	40	50	60	70	80	90	0
		Error ( μ m)										
0~1	Forward	0	0	0	+4	+6	+2	+2	0	0	+1	+1
	Return	+1	+2	+1	+5	+5	+4	+4	+1	0	+1	+1
1~2	Forward	+1	0	+1	+2	+3	+6	+5	+4	+2	+2	-1
	Return	+1	+1	+3	+4	+5	+6	+6	+3	+3	+1	+2
2~3	Forward	-1	+4	+2	+4	+8	+8	(+10)	+8	+8	+6	+6
	Return	+2	+4	+3	+4	+8	+9	+11	+8	+7	+7	+6
3~4	Forward	+6	+2	-1	-1	0	0	-1	0	-1	-1	-2
	Return	+6	+1	+1	0	+1	0	+2	0	+1	0	-2
4~5	Forward	-2	(-3)	-3	-3	-1	-1	-2	-2	-1	-2	-1
	Return	-2	-2	-2	-2	-1	-1	-2	0	0	0	0

## APPENDIX

### Calibration method for additional points

1. Usage range: The calibration of the indication error and the return error for the dial gauge with the reading in 0.01mm in service.
2. Equipment for calibration: Calibrator for dial gauges.
3. Technical requirements: The values in Table 11 should not be exceeded.
4. Calibration method: The calibration of the indication error for the dial gauge with the reading in 0.01 mm in service can be carried out on the basis of 20-scale division interval in the directions of the go and the return distance. After the calibration, if the indication errors of the measuring range and the optional 1 mm are close to values in Table 11, the calibration of the additional points in the area of the maximum, the minimum errors in the forward distance of travel and the maximum, the minimum

errors of the optional 1 mm should be carried out respectively.

During the calibration of the additional points the clamping position of the calibrated dial gauge should be kept the same as before. The calibrator should be adjusted to the positions 0.1 mm before and after the point of the maximum error in the go running distance for the additional points calibration respectively. If there is an error in an additional point that is bigger than the original maximum, this error of the additional point should be taken as maximum error.

Similarly, the calibration of the additional points should be carried out at the positions 0.1mm before and after the point of the minimum error in the forward distance of travel of the calibrated dial gauge. If there is an error in an additional point which is smaller than the original minimum, this error of the additional point should be taken as minimum error.

The same method should be used for the calibration of the additional points in the area



# ITTC – Recommended Procedures

**7.6-02-05**  
Page 11 of 11

## Sample Work Instructions Calibration of Dial Gauges

Effective Date  
2002

Revision  
00

of the maximum and the minimum errors for the optional 0.1 mm.

If the indication error of the adjacent points exceeds values of the indication error for the optional 0.1 mm in Table 11, a calibration of the middle point between these adjacent points should be carried out.

Table 14 shows the data treatment of the indication error and the return error for a dial gauge with the reading in 0.01 mm in service.

The indication error of the measuring range:  $11 - (-9) = 20 \mu\text{m}$

The indication error within the range of the optional 1mm:  $11 - 0 = 11 \mu\text{m}$

The indication error within the range of the optional 0.1 mm:  $11 - 5 = 6 \mu\text{m}$  (at the position 0.7~0.8mm of the first revolution)

The return error:  $0 - (-4) = 4 \mu\text{m}$

Table 14

Distance of travel (mm)	Calibrated point (scale division)							Optional 1mm	Optional 0.1mm	Whole distance error							
	0	20	40	60	80	0											
Error ( $\mu\text{m}$ )																	
0~1	Go	0	+2	+3	(+8)	+5	+1	8 (11)	6	20							
	R <sup>①</sup>	+1	+3	+5	+9	+6	+3										
1~2	Go	+1	+3	+4	+6	+6	+7	6			6	Return error					
	R	+3	+5	+5	+6	+5	+8										
2~3	Go	+7	-1	+1	-1	-1	-1	8		6			4				
	R	+8	+2	+3	0	0	-1										
3~4	Go	-2	-4	-3	-3	-1	-3	3	6			4					
	R	-1	-1	-2	-3	0	-1										
4~5	Go	-3	(-9)	-4	-4	-3	-3	6			6		4				
	R	-1	-6	0	-3	0	-1										
Calibration of additional points								Maximum		Minimum		Optional 0.1mm					
Distance of travel (mm)								0~1		4~5		2~3					
Calibrated point (scale division)								50	60	70		10	20	30	0	10	20
Indication error ( $\mu\text{m}$ )								+5	+8	+1		-5	-9	-6	+7	+3	-1

Note: ① means the return distance of travel.