	ITTC – Recommended Procedures	7.6-02-03 Page 1 of 10	
	Sample Work Instructions Calibration of Height Callipers	Effective Date 2002	Revision 00

CONTENTS

PURPOSE

WORK INSTRUCTION

- 1. Introduction**
- 2 Subject and Condition of Calibration.**
 - 2.1 Subject and Main Tools for Calibration of Height Calliper
 - 2.2 Calibration Conditions
- 3 Technical Requirements and Calibration Method**
 - 3.1 Exterior
 - 3.2 Relationship among parts
 - 3.3 Mutual positions among parts
 - 3.4 Width and its difference of scale mark
 - 3.5 Surface Roughness of Foot Measuring Plane and Foundation Working Plane
 - 3.6 Cutting Edge Thickness of Lining Measuring Foot
 - 3.7 Flatness of the Foot Measuring Plane and the Foundation Working Plane
 - 3.8 Size Tolerance Between Two Measuring Planes of Height Measuring Feet
 - 3.9 Parallelism of Foot Measuring Plane Against Foundation Working Plane at Same Flat Surface
 - 3.10 Correctness of Zero Position
 - 3.11 Tolerance of Indication
 - 3.12 Indication Stability of Number Display Device
 - 3.13 Error of Indication
- 4 Treatment of Calibration Result and Calibration Period**
 - 4.1 Treatment of calibration result
 - 4.2 Calibration period

Source:

Verification regulation of height caliper

[Issued on Oct. 18, 1999 and put into effect since Mar. 15, 2000 by National Technical Bureau - **JJG 31—1999, National Measuring Verification Regulation of People’s Republic of China**]

Prepared by	Approved
Quality Systems Group of 23 rd ITTC	23 rd ITTC 2002
Date	Date

	ITTC – Recommended Procedures	7.6-02-03 Page 2 of 10	
	Sample Work Instructions Calibration of Height Callipers	Effective Date 2002	Revision 00

Calibration of Height Callipers

PURPOSE

This working instruction can be applied to the verification of height of new callipers, or to the calibration of callipers in service and after repair, with scale division values 0.01, 0.02, 0.05 mm, and 0.10 mm, and with a measuring range up to 1000mm.

WORK INSTRUCTION

1. Introduction

A height calliper is a tool for measuring the mutual position of products above a surface and for precisely drawing lines. The main construction types are vernier height calliper (Fig.1), electronic number display height calliper (Fig.2), dial indicator height calliper (Fig.3) and counting type dial indicator height calliper (Fig.4) respectively.

2 Subject and Condition of Calibration.

2.1 Subject and Main Tools for Calibration of Height Calliper

The items and the main tools of the calibration for height callipers are listed in Table 1.

2.2 Calibration Conditions

2.2.1 The room temperature must be in the range of $(20 \pm 5)^\circ\text{C}$

2.2.2 The relative humidity of the room

should not exceed 80%.

2.2.3 Time of the temperature balance during the calibration

Before the calibration, the calibrated height calliper, the measuring blocks and the other calibration tools must be kept on the levelling plate in the room to achieve temperature equilibrium, for no less than the times given in Table 2.

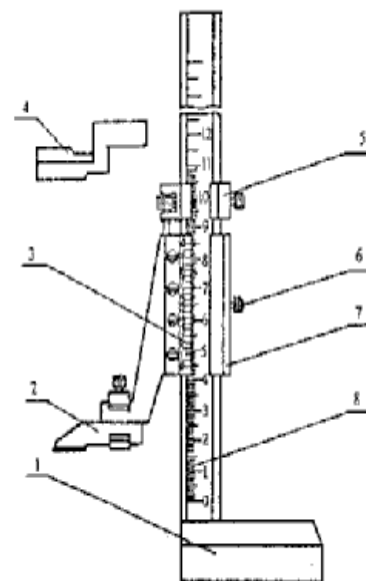

Fig. 1 vernier height calliper

Where, 1 foundation; 2 lining measuring foot; 3 vernier; 4 height measuring feet; 5 final motion device; 6 fastening screw; 7 calliper frame; 8 main scale ruler

3 Technical Requirements and Calibration Method

3.1 Exterior

3.1.1 Requirements

3.1.1.1 The cladding material on the surface of the height calliper should be well distributed. The scale mark and the counter should be clear. The watch glass should be transparent and clear. The height calliper should not have any rust, mechanical damage, plating layer damage, obvious scoring, any visible line breaks or uneven thickness, and any other fault which affects its exterior quality.

3.1.1.2 The name of the manufacturer or the trademark, the scale division value, the sign of and the production serial number should be marked on the calliper.

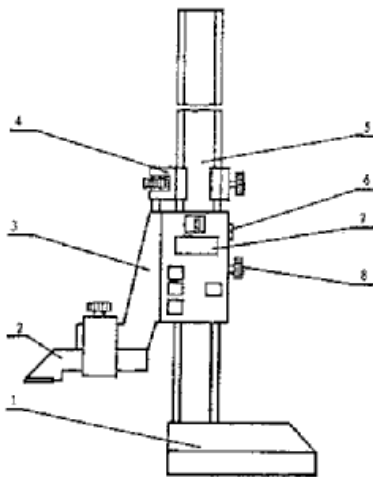

Fig.2 electronic number display height calliper

Where, 1 foundation; 2 lining measuring foot; 3 calliper frame; 4 final motion device; 5 raster scale ruler; 6 zero clearing

button; 7 number display device; 8 fastening screw

3.1.1.3 The height calliper in service and after repair should not have any exterior fault which affects its accuracy.

3.1.2 Calibration Method: Observed visually.

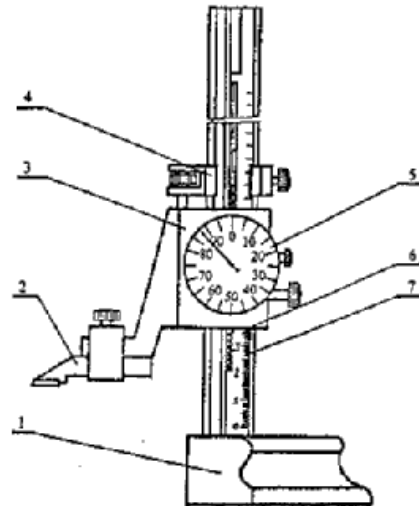

Fig.3 dial indicator height calliper

Where, 1 foundation; 2 lining measuring foot; 3 calliper frame; 4 final motion device; 5 dial indicator; 6 millimetre reading area; 7 main scale ruler

Table 2

Measuring range (mm)	Time for temperature equilibrium (h) On levelling plate
≤300	1.0
>300~500	1.5
>500~2000	2.0

	ITTC – Recommended Procedures	7.6-02-03 Page 4 of 10	
	Sample Work Instructions Calibration of Height Callipers	Effective Date 2002	Revision 00

Table 1

No	Item	Main calibration tools	Sort of calibration		
			New product	In service	After repair
1	Exterior	-----	+	+	+
2	Relationship among parts	-----	+	+	+
3	Mutual positions among parts	Plug gauge	+	-	+
4	Width & its difference of scale mark	Tool microscope	+	-	-
5	Surface roughness of foot measuring plane and foundation working plane	Sample block for comparison of surface roughness	+	-	+
6	Cutting edge thickness of lining measuring foot	Plug gauge or tool microscope	+	+	+
7	Accuracy of foot measuring plane and foundation working plane	Zero & first class tool edge ruler	+	+	+
8	Size tolerance between two measuring planes of height measuring feet	Micrometer, micrometer caliper with error allowance 0.001mm	+	+	+
9	Parallelism of foot measuring plane against foundation working plane at same flat surface	First class levelling plane, dial test indicator with scale division value 0.002mm	+	+	+
10	Correctness of zero position	First class levelling plane	+	+	+
11	Tolerance of indication	Third class or sixth grade measuring block, first class levelling plane	+	+	-
12	Indication stability of number display device	---	+	+	+
13	Error of indication	Third class or sixth grade measuring block, first class levelling plane	+	+	+

Note: “+” means calibration must be done; “-” means calibration may not be done

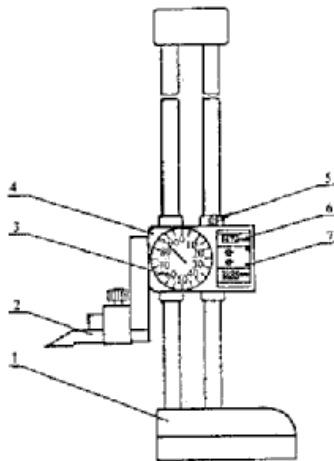

Fig. 4 counting type dial indicator height calliper

Where, 1 foundation; 2 lining measuring foot; 3 dial indicator; 4 calliper frame; 5 fastening handle; 6 millimetre counter; 7 zero clearing button

3.2 Relationship among parts

3.2.1 Requirements

3.2.1.1 It should be possible to move the calliper frame steadily against the calliper body by hand without any seizure or falling under its own weight. The number display should be clear and fine without any blank spots, or unsteadiness. The functions of the buttons should work reliable and steadily.

3.2.1.2 The fastening screw should work reliably. The idle movement of the final motion device should not exceed one-quarter and one-half circle.

3.2.2 Calibration method: Observed visually and tested by hand.

3.3 Mutual positions among parts

3.3.1 Requirements

3.3.1.1 The distance between the scale mark surface edge of the vernier and the scale mark surface of the main scale ruler should not exceed 0.3mm.

3.3.1.2 The tip of the pointer hand of the dial indicator should cover 30% ~ 80% of the shorter mark length. The gap between the tip of the pointer hand and the surface of the scale mark should not exceed the values given in Table 3.

Table 3 (mm)

Scale division value	Gap between the tip of the pointer hand and scale mark surface
0.01, 0.02	0.7
0.05	1.0

3.3.2 Calibration method: observed visually or calibrated with the comparison method using a plug gauge.

3.4 Width and its difference of scale mark

3.4.1 Requirements

3.4.1.1 The widths and its differences between the scale marks for the main scale ruler and the vernier of the vernier height calliper should not exceed the values shown in Table 4.

3.4.1.2 The widths of the main scale ruler mark for the dial indicator height calliper and the scale mark for the dial indicator, as well as the width of the tip end for the point hand should be 0.10 ~ 0.20mm. The difference of the width should be no larger than 0.04mm.

	ITTC – Recommended Procedures	7.6-02-03 Page 6 of 10	
	Sample Work Instructions Calibration of Height Callipers	Effective Date 2002	Revision 00

Table 4 (mm)

Scale division value	Width of scale mark	Width difference of scale mark
0.02	0.08~0.18	0.02
0.05		0.03
0.10		0.05

3.4.2 Calibration Method

The calibration can be made by use of a tool microscope. At least three of the lines of the main scale ruler, the vernier and the dial indicator, should be selectively calibrated. The width difference of the mark should be determined as the difference between the maxima and minima of the calibrations.

3.5 Surface Roughness of Foot Measuring Plane and Foundation Working Plane

3.5.1 Requirement: The values written in Table 5 should not be exceeded.

Table 5

Scale division value (resolution) (mm)	Surface roughness $R_a(\mu\text{m})$	
	Measuring plane of measuring feet	Working plane of foundation
0.01, 0.02	0.2	0.4
0.05, 0.10	0.4	

3.5.2 Calibration Method: Calibration may be carried out using a sample block for the comparison of the surface roughness.

3.6 Cutting Edge Thickness of Lining Measuring Foot

3.6.1 Requirement: The cutting edge thickness of the lining measuring foot should be $(0.15 \pm 0.05)\text{mm}$.

3.6.2 Calibration method

Calibration may be carried out by the use of a tool microscope or a plug gauge, when placed on a levelling plate.

3.7 Flatness of the Foot Measuring Plane and the Foundation Working Plane

3.7.1 Requirement: The values shown in Table 6 should not be exceeded.

Table 6 (mm)

Measuring range	Flatness of Measuring plane of measuring feet	Flatness of working plane of foundation
0 ~ 1000	0.003	0.005
> 1000 ~ 2000	0.004	0.006

Note: This cannot be considered within the area of 1 mm from the edge of the foundation profile. Hollow on the working plane is allowed.

3.7.2 Calibration Method: The foot measuring plane and the foundation working plane can be calibrated by use of zero or first class tool edge rulers using the light test method. The calibration can be made at the positions of the long edge, the short edge and the diagonal for the foot measuring plane and the foundation working plane. The flatness can be determined on the basis of the gaps from all the directions. When

gaps appear in all the calibrated directions, and are all in the middle position or all at the end edge, the maximum gap at one direction should be taken as the flatness. When some of the gaps are in the middle position and the others are at the end edge, the sum of both the maximum gaps in the middle position and at the end edge should be taken as the flatness.

3.8 Size Tolerance Between Two Measuring Planes of Height Measuring Feet

3.8.1 Requirements

The working size of the height calliper measuring foot should be an integral number of mm for a new calliper. For callipers in service and after repair, it is allowed to be the integral number of their scale division value. The size tolerance between two measuring planes of height measuring feet should not exceed the values written in Table 7.

Table 7 (mm)

Scale division Value (resolution)	Working size deviation of height measuring foot	Size tolerance between two measuring planes of height measuring feet
0.01, 0.02	±0.01	0.003
0.05	±0.02	0.005
0.10	±0.03	0.010

3.8.2 Calibration method

The working size deviation of the height measuring foot can be calibrated by use of a

micrometer. The size tolerance between two measuring planes of the height measuring feet can be calibrated by use of a micrometer calliper with error allowance 0.001mm. The size tolerance can be obtained from the difference between the maximum and the minimum sizes.

3.9 Parallelism of Foot Measuring Plane Against Foundation Working Plane at Same Flat Surface

3.9.1 Requirement: The values in Table 8 should not be exceeded.

Table 8 (mm)

Scale division value (resolution)	Parallelism of foot measuring plane against foundation working plane at same flat surface
0.01, 0.02	0.005
0.05, 0.10	0.010

3.9.2 Calibration Method

The calliper frame should be moved until the measuring plane touches the levelling plane normally, while the height calliper is kept on the first levelling plane. The calibration can be carried out by use of a dial test indicator with scale division value 0.002mm, as shown in Figure 5.

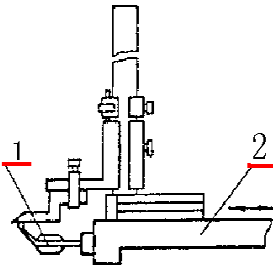

Fig. 5
Where, 1 dial test indicator; 2 levelling plane

3.10 Correctness of Zero Position

3.10.1 Requirements

3.10.1.1 The “zero” and the “end” marks on the vernier should coincide with the relevant marks on the main scale ruler when the foot measuring plane is touching the levelling plane. The limit deviation of the degree of coincidence is listed in Table 9.

Table 9 (mm)

Scale division value	Degree of coincidence of zero mark	Degree of coincidence of tail mark
0.02	±0.005	±0.010
0.05	±0.005	±0.020
0.10	±0.010	±0.030

3.10.1.2 The pointer hand of the dial indicator should be directly in the upwards position, when the foot-measuring plane touches the levelling plane. At the same time the distance of the millimetre reading area and the “zero” mark of the main scale ruler should not be bigger than the mark width and the coincidence of both the marks should not be bigger than the half the

mark width.

3.10.2 Calibration Method

The calliper frame is moved until the foot measuring plane touches normally the levelling plane (if the calliper has a final motion device, it should be used) while the height calliper is kept on the levelling plane. Then it can be observed visually and if necessary, calibrated by use of a tool microscope at two conditions of the frame, that is fastened and unfastened.

3.11 Tolerance of Indication

3.11.1 Requirements

The tolerance of indication for the height vernier calliper and the dial indicator height calliper should not exceed half of the scale division value. That of the height calliper with the number display device should not exceed 0.01mm.

3.11.2 Calibration method

The frame should be put at any random position under the same condition so that the measuring plane of the measuring foot can repeatedly touch the measuring block or the levelling plane ten times, the values should be read. The tolerance of indication can be obtained from the difference of the maximum and the minimum readings.

3.12 Indication Stability of Number Display Device

3.12.1 Requirements: The indication should not exceed 0.01mm within one hour.

3.12.2 Calibration method

The display can be calibrated visually. The change in the displayed value within one

	ITTC – Recommended Procedures		7.6-02-03 Page 9 of 10	
	Sample Work Instructions Calibration of Height Callipers		Effective Date 2002	Revision 00

hour, should not exceed the values below in Table 10, with the frame fastened at any position in the measuring range.

3.13 Error of Indication

3.13.1 Requirements

The indication error should not exceed the values shown in Table 10.

Table 10 (mm)

measuring range	Scale division value (resolution)		
	0.01, 0.02	0.05	0.10
	Indication error		
0 ~ 150	±0.02	±0.05	±0.10
>150 ~ 200	±0.03	±0.05	±0.10
>200 ~ 300	±0.04	±0.08	±0.10
>300 ~ 500	±0.05	±0.08	±0.10
>500 ~ 1000	±0.07	±0.10	±0.15
>1000 ~ 1500	±0.10	±0.15	±0.20
>1500 ~ 2000	±0.14	±0.20	±0.25

3.13.2 Calibration Method

A third class measuring block or a sixth grade-measuring block should be put on a first class levelling plane for the calibration. For height callipers with a measuring range of 300 mm, at least three calibrated points should be well-distributed, for instance, the calibrated points might be 101.3, 201.6 and, 291.9 or 101.2, 201.5 and 291.8, for a measuring length of 0 to 300 mm. For height callipers with a measuring range beyond 300 mm, at least six calibrated points should be well distributed, for instance, the calibrated points might be 80.0, 161.3, 240.0, 321.6, 400.0, and 491.9 or 80.0, 161.2, 240.0, 321.5, 400.0, and 491.8, for a measuring length of 0 to 500 mm. The

number of points can be increased on basis of the actual condition.

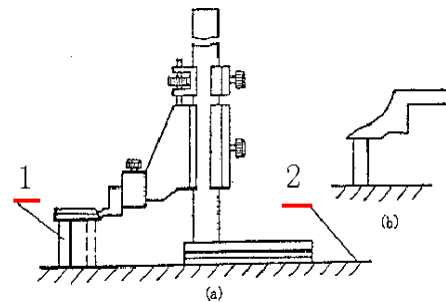



Fig. 6
Where, 1 measuring block; 2 levelling plane

During the calibration, the measuring foot should be put to the position of the maximum length that can be reached. Every point should be calibrated at two positions, using the inside and outside of the measuring foot, as shown in Figure 6 (a).

For the lining measuring foot the calibration can be only carried out at a position, shown in Figure 6 (b). The calibration should be carried out under the conditions of the screw being fastened and unfastened. The measuring plane of the measuring foot and the surface of the measuring block should normally be able to be moved, when touching each other whether the screw is fastened or not. In the case of touching contact, the final motion device should be used. The difference between the readings of the calibrated point and the block size are taken as the indication error of this point.

	ITTC – Recommended Procedures	7.6-02-03 Page 10 of 10	
	Sample Work Instructions Calibration of Height Callipers	Effective Date 2002	Revision 00

4 Treatment of Calibration Result and Calibration Period

calibration result will be supplied and the calliper will be so marked.

4.1 Treatment of calibration result

For height callipers which meet the requirement of this working instruction through calibration, a calibration report will be supplied; For the ones which do not meet the requirements a notice of the non-compliance of the

4.2 Calibration period

The calibration period can be determined upon the service condition, but not longer than one-year.