	<b>ITTC – Recommended Procedures</b>	<b>7.6-02-02</b> Page 1 of 11	
	<b>Sample Work Instructions Calibration of Vernier Callipers</b>	Effective Date 2002	Revision 00

## CONTENTS

### PURPOSE

- 1. Introduction**
- 2. Subject and Condition of Calibration**
  - 2.1 Subject and Main Tools of Calibration
  - 2.2 Calibration Conditions
- 3. Technical requirements and calibration method**
  - 3.1 Exterior
  - 3.2 Relationship among Parts
  - 3.3 Distance between Calliper Body Engraved Plane and Edge of Vernier Engraved Plane
  - 3.4 Difference of the Width Between Lines
  - 3.5 Surface Roughness of Measuring Plane
  - 3.6 Accuracy of Measuring Plane of Outside Measuring Feet.
  - 3.7 Fold Gap of Both Measuring Planes of Outside Measuring Feet
  - 3.8 Size and Parallelism of Inside Measuring Arc Feet
  - 3.9 Size and Parallelism of Inside Measuring Tool Edge Feet
  - 3.10 . Error of Zero Value
  - 3.11 Error of Indication
- 4 Treatment of the calibration result**

### Source

#### Verification regulation of Vernier calliper

[Issued on June 23, 1992 and put into effect since Dec. 1, 1992 by National Technical Bureau - **JJG 30—1992, National Measuring Verification Regulation of People’s Republic of China**]

Prepared by	Approved
Quality Systems Group of 23 <sup>rd</sup> ITTC	23 <sup>rd</sup> ITTC 2002
Date	Date

## Calibration of Vernier Callipers

### PURPOSE

This working instruction can be applied to the verification of new vernier callipers or the calibration of vernier callipers in service and after repair with scale division values of 0.02, 0.05 and 0.10 mm and with a measuring range up to 1000mm.

### 1. Introduction

Vernier callipers are mainly used to measure the outer and inner size of parts. Their main construction types are shown in Fig.1 to Fig.4 respectively.

### 2. Subject and Condition of Calibration

#### 2.1 Subject and Main Tools of Calibration

The subject and the main tools of the cali-

bration for vernier callipers are listed in Table 1.

#### 2.2 Calibration Conditions

2.2.1 The temperature of the room must be in the range of  $(20\pm 3)^\circ\text{C}$  and  $(20\pm 5)^\circ\text{C}$  when vernier callipers with scale division values of 0.02mm and 0.05, 0.10 mm respectively are calibrated.

2.2.2 Time of the temperature balance during the calibration.

Before the calibration the calibrated vernier calliper and the measuring blocks must be kept on the metal plate or on a wooden table in the room for the temperature equilibrium for no less than the values given in Table 2.

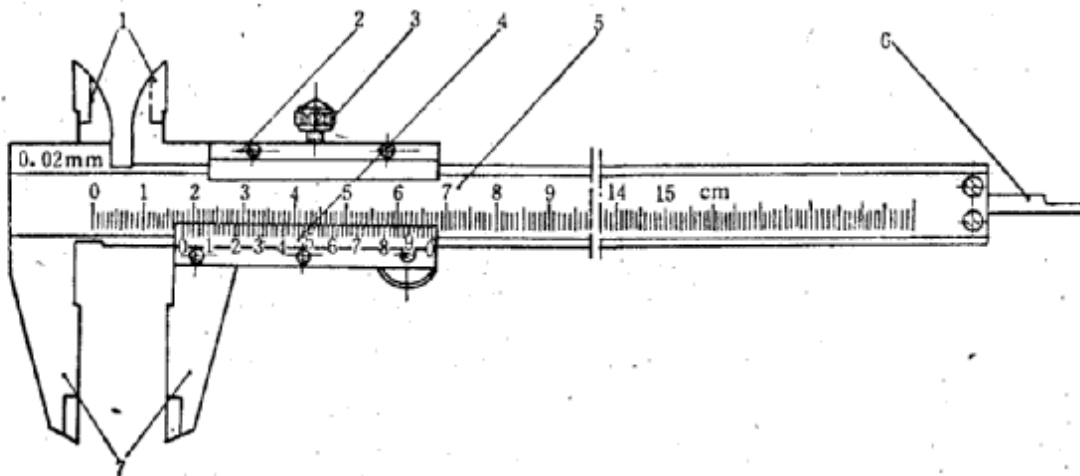

Fig.1

Where, 1 inside measuring tool edge feet; 2 calliper frame; 3 fastening screw; 4 vernier; 5 calliper body; 6 ruler for measuring depth; 7 outside measuring feet

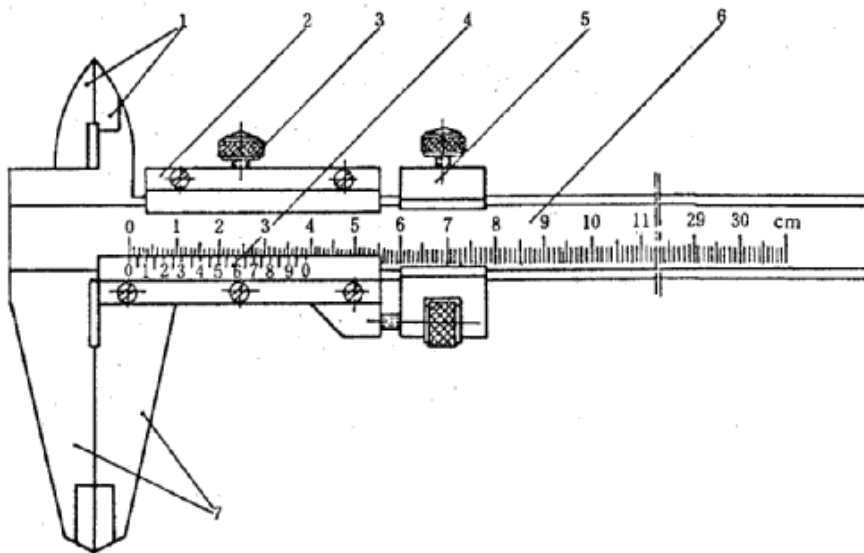

Fig.2

Where, 1 inside measuring tool edge feet; 2 calliper frame; 3 fastening screw; 4 Vernier; 5 final motion device; 6 calliper body; 7 outside measuring feet

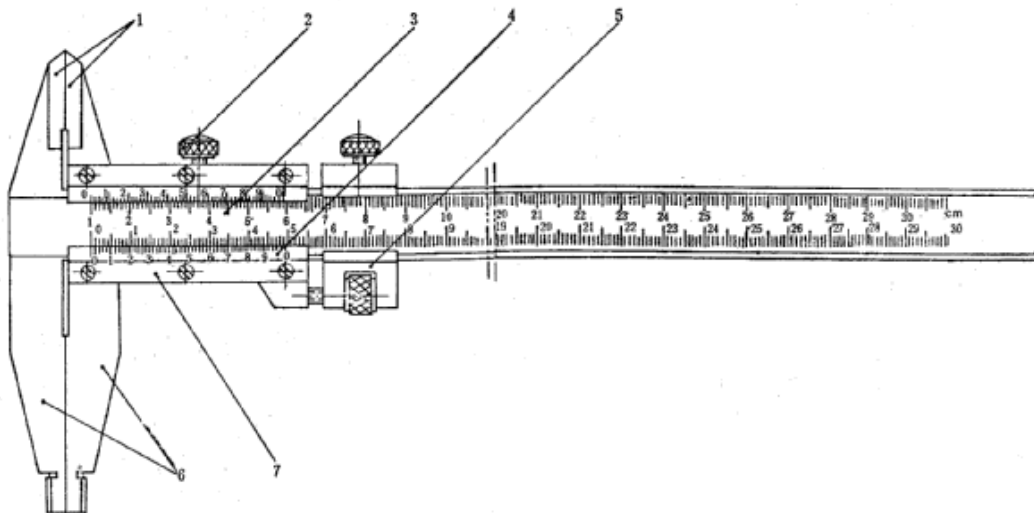

Fig.3

Where, 1 outside measuring tool edge feet; 2 fastening screw; 3 calliper body; 4 vernier; 5 final motion device; 6 feet of inside measuring arc and outside measuring; 7 calliper frame

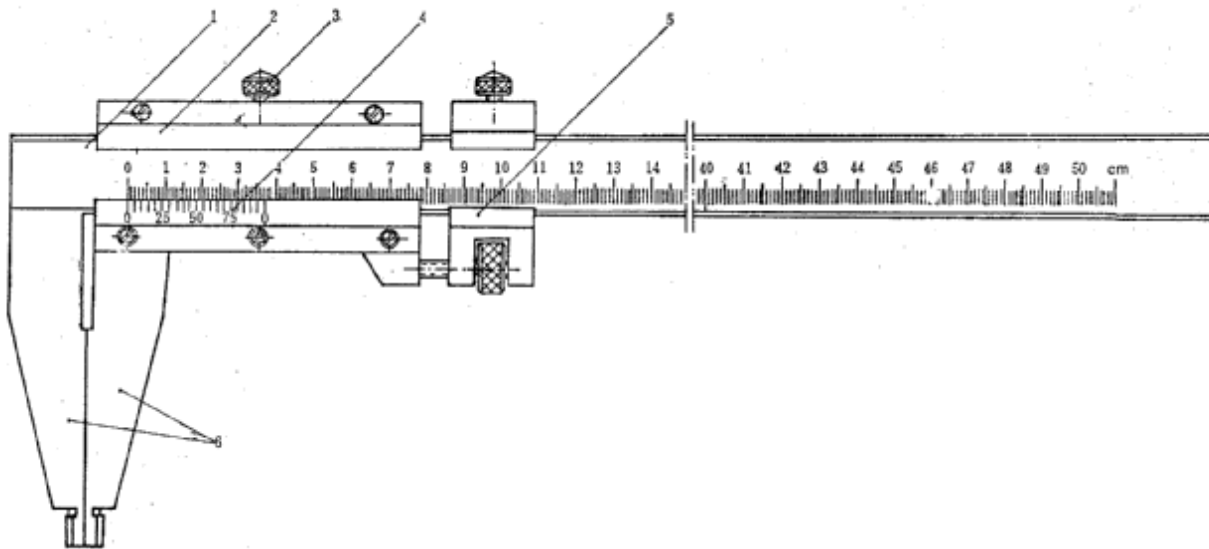

Fig. 4

Where, 1 calliper body; 2 calliper frame; 3 fastening screw; 4 vernier; 5 final motion device; 6 feet of inside measuring arc and outside measuring;

Table 2

Measuring upper limit	Time for temperature equilibrium (h)	
	On wooden table	On metal plate table
≤300	2	1.0
>300~500	3	1.5
>500~1000	4	1.5

### 3. Technical requirements and calibration method

#### 3.1 Exterior

##### 3.1.1 Requirements

The vernier calliper should not have any mechanical damage, rust or any other damage on its surface. The lines and the numbers must be clear and well distributed without any fading.

The lines on the vernier should be engraved to its lower side on the angular surface.

The scale division value, the name of the manufacturer, the mark of the factory and the serial number of production should be marked on the calliper.

The vernier calliper in service or after a repair should not have any exterior default which affects its accuracy.

##### 3.1.2 Calibration method: By eyesight.

#### 3.2 Relationship among Parts

##### 3.2.1 Requirements

The calliper frame can be steadily moved against the calliper body without any friction. The fastening screw should work reliably. The ruler for depth measuring is not allowed to have any free sliding movement itself. The idle running of the final motion device should not

	<b>ITTC – Recommended Procedures</b>	<b>7.6-02-02</b> Page 5 of 11	
	<b>Sample Work Instructions</b> <b>Calibration of Vernier Callipers</b>	Effective Date 2002	Revision 00

exceed one-fourth and one-half circle for a new and a vernier calliper in service or after repair respectively. The join of the calliper body and the frame should not have any obvious movement.

Table 1

No	Item	Main calibration tools	Sort of calibration		
			New product	In service	After repair
1	<b>Exterior</b>	-----	+	+	+
2	<b>Relationship among parts</b>	-----	+	+	+
3	Distance between vernier engraved plane edge and calliper body engraved plane	<b>Second class plug gauge</b>	+	-	+
4	Width & its difference of lines	Tool microscope	+	-	+
5	Surface roughness of measuring plane	Sample block for comparison of surface roughness	+	-	+
6	Accuracy of the measuring plane of outside measuring feet	Second class optical flat or zero class and first class sample ruler	+	+	+
7	Fold gap of both measuring planes of outside measuring feet	-----	+	+	+
8	<b>Size and parallelism of inside measuring arc feet</b>	<b>Outside micrometer</b>	+	+	+
9	Size and parallelism of inside measuring tool edge feet	10mm third class measuring block, outside micrometer	+	+	+
10	<b>Error of zero value</b>	Magnifier or tool microscope	+	+	+
11	<b>Error of indication</b>	<b>Third class or sixth grade measuring block</b>	+	+	+
<b>Note: “+” means calibration must be done; “-” means calibration may not be done</b>					

3.2.2 Calibration Method: observation and testing.

The quality of fit between the body and the frame can be observed and calibrated with a

movable measuring foot which is lightly swung by hand.

3.3 Distance between Calliper Body Engraved Plane and Edge of Vernier Engraved Plane

3.3.1 Requirement: The values in Table 3 should not be exceeded.

3.3.2 Calibration Method: The calibration can be performed by comparison with a second class plug gauge, as shown in Figure 5.

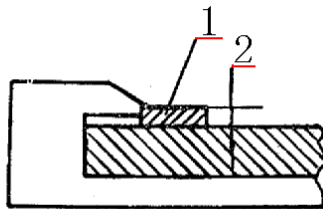

Fig. 5

Where, 1 plug gauge; 2 distance

### 3.4 Difference of the Width Between Lines

#### 3.4.1 Requirement

The values in Table 4 should not be exceeded.

Table 3 (mm)

Scale division value	Measuring upper limit	
	≤500	>500
0.02	0.20	0.25
0.05	0.22	0.27
0.10	0.25	0.30

Table 5

Scale division value (mm)	Surface roughness $R_a(\mu\text{m})$		
	Measuring plane of outside measuring feet	Measuring plane of inside measuring feet	End edge of calliper body with depth measuring ruler
0.02	0.2	0.4	0.8
0.05, 0.10	0.4	0.4	0.8

Table 4 (mm)

Scale division value	Width of lines	Width difference of lines
0.02	0.08~0.12	0.02
0.05	0.08~0.15	0.03
0.10	0.08~0.20	0.05

#### 3.4.2 Method of Calibration

It can be calibrated by the use of a reading microscope. At least three of the lines of the calliper body and the vernier should be each selectively calibrated respectively. The line width difference can be decided from the difference between the maximum width and the minimum one of the calibrated line.

### 3.5 Surface Roughness of Measuring Plane

3.5.1 Requirement: The values in Table 5 should not be exceeded.

#### 3.5.2 Calibration method

A comparing method with a sample block for the surface roughness may be used.

	<b>ITTC – Recommended Procedures</b>	<b>7.6-02-02</b> Page 7 of 11	
	<b>Sample Work Instructions Calibration of Vernier Callipers</b>	Effective Date 2002	Revision 00

### 3.6 Accuracy of Measuring Plane of Outside Measuring Feet.

3.6.1 Requirement: The values in Table 6 should not be exceeded.

Table 6 (mm)

Scale division value	Accuracy of measuring plane of outside measuring feet
0.02	0.002
0.05, 0.10	0.005

Note: Sinkage at the side is allowed within the range 0.2mm from the edge of the measuring plane.

#### 3.6.2 Calibration Method

A calliper with a scale division of 0.02 mm can be calibrated using a second class optical flat or a zero class sample ruler; callipers with scale divisions of 0.05 or 0.10 mm can be calibrated using a first class sample ruler.

An interference fringe of any shape should be shown on the whole measuring plane when the calliper is calibrated by use of an optical flat. The positioning of the sample ruler is shown in Figure 6 with the dotted lines when the calliper is calibrated by use of the sample ruler on the basis of the standard light test method. The accuracy of the measuring plane can be obtained observing the gaps from all the directions. When the observed gaps at all calibrated directions are all in the middle position or all at the end edge, the maximum gap in one direction should be taken as the accuracy of the measuring plane. When some of the gaps are in the middle position and the others are at the end edge, the sum of both the maximum gaps in the middle position and at the end edge should be taken as the accuracy of the measuring plane.

### 3.7 Fold Gap of Both Measuring Planes of Outside Measuring Feet

3.7.1 Requirement: The values in Table 7 should not be exceeded.

Table 7 (mm)

Scale division value	Fold gap of both measuring planes of outside measuring feet
0.02	0.006
0.05, 0.10	0.010

#### 3.7.2 Calibration Method

The calliper frame should be moved until both the measuring planes of the measuring feet are touching, as felt by hand; then the gap between the measuring planes can be observed by eyesight and calibrated by use of the light test method. This calibration should be carried out at two conditions with the frame being fastened and unfastened respectively.

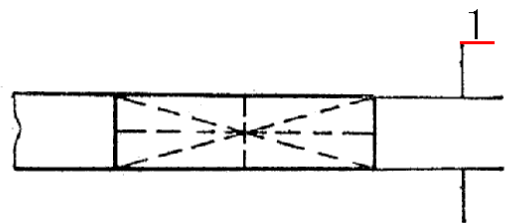



Fig. 6

Where, 1 width of measuring plane

### 3.8 Size and Parallelism of Inside Measuring Arc Feet

#### 3.8.1 Requirements

The fundamental size of the inside measuring arc feet of a new calliper should be in total

	<b>ITTC – Recommended Procedures</b>	<b>7.6-02-02</b> Page 8 of 11	
	<b>Sample Work Instructions</b> <b>Calibration of Vernier Callipers</b>	Effective Date 2002	Revision 00

10 mm or 20 mm when the two feet are touching. The fundamental size is allowed to be a total of 0.1 mm off for a calliper in service and after repair; that ensures it will be the integral multiple of the scale division value of the vernier calliper used. This deviation must be noted in the protocol.

The deviations in the size and parallelism of the inside measuring arc feet should not exceed the values in Table 8.

Table 8 (mm)

Scale division value	Size deviation of inside measuring arc feet	parallelism
0.02	±0.01	0.01
0.05	±0.02	
0.10	±0.03	

Note: Sink is allowed within the range 0.5mm at the outer edge for the calliper in service and after repair.

### 3.8.2 Calibration Method

The fundamental size can be calibrated by use of an outside micrometer in the direction parallel to the calliper body along the inside measuring feet. The difference between the fundamental size and the value measured in any other directions should not exceed the upper limit of the feet size deviation.

The parallelism can be measured at the position 2 mm from the outer end of the inside measuring feet parallel to the direction of the calliper body, as shown in Figure 7. It can be determined from the difference of the maximum and the minimum value over the whole length of the inside measuring feet.

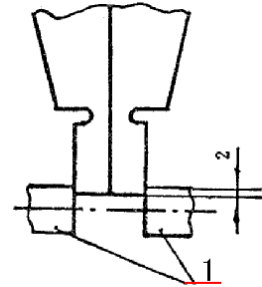

Fig. 7

Where, 1 gauge button of micrometer

The difference of the measured values and the block in any other direction should not exceed the upper limit of the deviation of the

### 3.9 Size and Parallelism of Inside Measuring Tool Edge Feet

3.9.1 Requirement: The deviation should not exceed the values in Table 9 when the calibrated size is 10 mm

#### 3.9.2 Calibration method

A one piece third class measuring block 10 mm in length is clamped with its long side between the two measuring planes of the outside measuring feet. After the fastening screw has been fixed, the block should be able to slide but not fall. The size of the inside measuring tool edge feet can be measured by the use of an outside micrometer with the measuring force 6N ~ 7N, along the inside measuring tool edge feet, in the direction of the calliper body. The deviation can be obtained from the difference of the measured value and the block size, inside the measuring tool edge feet.

The parallelism can be measured by the use of an outside micrometer along the measuring feet parallel to the direction of the calliper body. It can be determined from the difference of the

maximum and minimum values, over the whole length of the inside measuring tool edge feet.

Table 9 (mm)

Scale division value	Size deviation of inside measuring tool edge feet		Parallelism	
	New product and after repair	In service	New product and after repair	In service
0.02	+0.020 +0.005	+0.020 -0.010	0.010	0.010
0.05	+0.035 +0.010	+0.035 -0.015		0.015
0.10	+0.050 +0.015	+0.050 -0.020		

### 3.10. Error of Zero Value

3.10.1 Requirement: It can be expressed with the degree of coincidence of the zero line and the tail line. It should not exceed the values in Table 10.

Table 10 (mm)

Scale division value	Coincidence degree of zero line	Coincidence degree of tail line
0.02	±0.005	±0.01
0.05	±0.005	±0.02
0.10	±0.010	±0.03

### 3.10.2 Calibration method

The calliper frame can be moved until both the measuring planes touch each other (if the calliper has a final motion device, it should be used). Then the measuring planes can be observed by eye and if necessary, calibrated by use of a magnifier or a tool microscope in two

conditions with the frame fastened and unfastened respectively.

### 3.11 Error of Indication

#### 3.11.1 Requirement

The indication error should not exceed the values in Table 11.

Table 11 (mm)

Size range	Scale division value		
	0.02	0.05	0.10
	Indication error		
0 ~ 300	±0.02	±0.050	±0.10
>300 ~ 500	±0.04	±0.050	±0.10
>500 ~ 700	±0.05	±0.075	±0.10
>700 ~ 900	±0.06	±0.100	±0.15
>900 ~ 1000	±0.07	±0.125	±0.15

### 3.11.2 Calibration method

A third class measuring block or a sixth grade-measuring block should be prepared for the calibration. For the calliper with the measuring range of 300 mm at least three calibration points should be well-distributed, for instance, the calibrated points might be 101.3, 201.6 and 291.9 or 101.2, 201.5 and 291.8 for the calliper with a measuring length from 0 to 300 mm. For a calliper with the measuring range beyond 300 mm, at least six calibrating points should be well-distributed, for instance, the calibrated points might be 80.0, 161.3, 240.0, 321.6, 400.0 and 491.9 or 80.0, 161.2, 240.0, 321.5, 400.0 and 491.8 for a calliper with a measuring length from 0 to 500 mm. The number of points can be increased on the basis of the actual condition.

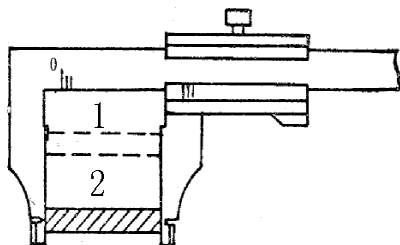

Fig. 8

Where, 1 inside; 2 outside

Each point should be calibrated at the two positions: inside and outside of the measuring feet. The long side of the working plane of the measuring block should be perpendicular to the long side of the measuring plane of the calliper, as shown in Figure 8. The calibration should be carried out at the conditions of the fixing screw fastened and unfastened. When the measuring plane of the calliper and the surface of the

measuring block are touching each other the block normally can be moved whether the screw is fastened or not. The difference between the value of the reading at the calibrated point and the block size can be taken as the indication error at this point. The difference of readings for the inside and the outside for every calibrated point should not exceed the values given in Table 12

Table 12 (mm)

Size range	Scale division value		
	0.02	0.05	0.10
Difference of inside and outside at calibrated point			
0 ~ 200	0.01	0.03	0.05
>200 ~ 500	0.02	0.05	0.05
<500 ~ 1000	0.04	0.05	0.10

The calibration method for the indication error of the outside measuring tool edge feet is the same as above. The measuring block should be located in the middle position of the outside measuring tool edge feet at the time of the calibration.

For the calliper with the depth ruler, the calibration can be made at the point of the length 20 mm of the depth ruler. Two measuring blocks with the size 20 mm can be put on a first class plate. The end edge of the calliper body should touch the blocks and the depth ruler can be stretched to the working plane of the plate. The value can be read from the calliper body. Its indication error should not exceed the scale division value of the vernier calliper.

	<b>ITTC – Recommended Procedures</b>		<b>7.6-02-02</b> Page 11 of 11	
	<b>Sample Work Instructions</b> <b>Calibration of Vernier Callipers</b>		Effective Date 2002	Revision 00

#### 4 Treatment of the calibration result

4.1 For vernier callipers which meet the requirements of this working instruction a calibration certificate will be supplied. For ones which do not meet the requirements a notice of

the calibration result will be applied.

4.2 The calibration period can be determined upon the frequency and condition of use, , but not longer than one-year.