	ITTC – Recommended Procedures	7.5-02 -03-02.1 Page 1 of 9	
	Testing and Extrapolation Methods Propulsion, Propulsor Open Water Test	Effective Date 2002	Revision 01

CONTENTS

1 PURPOSE OF PROCEDURE

2 PARAMETERS:

2.1 Data Reduction Equations

2.2 Definition of Variables

3 PROCEDURE

3.1 Model and Installation

3.1.1 Model

3.1.2 Installation

3.1.2.1 Conventional Propellers

3.1.2.2 Ducted Propellers

3.2. Measurement Systems

3.3. Instrumentation

3.3.1. General remarks

3.3.2. Thrust

3.3.3. Torque

3.3.4. Rate of revolution

3.3.5. Speed

3.3.6. Temperature

3.4. Calibrations

3.4.1. General remarks

3.4.2. Propeller dynamometer:

3.4.2.1. Propeller Thrust

3.4.2.2 Propeller Torque

3.4.3. Rate of revolution

3.4.4. Speed

3.4.5. Thermometer

3.5. Test Procedure and Data Acquisition

3.6. Data Reduction and Analysis

3.7. Documentation

4. VALIDATION

4.1 Uncertainty Analysis

4.2 Benchmark Tests

5. REFERENCES

Updated by	Approved
Specialist Committee of 23 rd ITTC: Procedures for Resistance, Propulsion and Propeller Open Water Tests	23 rd ITTC 2002
Date	Date 2002

 ITTC INTERNATIONAL TOWING TANK CONFERENCE	ITTC – Recommended Procedures	7.5-02 -03-02.1 Page 2 of 9	
	Testing and Extrapolation Methods Propulsion, Propulsor Open Water Test	Effective Date 2002	Revision 01

Open Water Tests

1 PURPOSE OF PROCEDURE

The purpose of the procedure is to ensure consistency of methodology and acquisition of correct results from Propeller Open Water Tests.

The propeller open water characteristics are used in the analysis of the Propulsion Tests and the estimation of the required power. The procedure addresses model scale only and does not consider extrapolation and full scale prediction.

The procedure is generally applicable for open water tests performed with conventional propellers, ducted propellers and tip-plate propellers.

2 PARAMETERS:

2.1 Data Reduction Equations

 Thrust Coefficient

$$K_T = \frac{T}{\rho \cdot n^2 D^4}$$

Torque Coefficient

$$K_Q = \frac{Q}{\rho \cdot n^2 D^5}$$

Ducted Propeller

Duct Thrust Coefficient

$$K_{TD} = \frac{T_D}{\rho \cdot n^2 D^4}$$

Thrust Coefficient

$$K_{TP} = \frac{T_P}{\rho \cdot n^2 D^4}$$

Total thrust coefficient for a ducted propeller unit $K_{TT} = K_{TP} + K_{TD}$

Propeller Efficiency in

Open Water

$$\eta_o = \frac{JK_T}{2\pi K_Q}$$

Advance Coefficient

$$J = \frac{V_A}{nD}$$

Reynolds Number of propeller
 Based on chord length $0.7R$

$$Re = \frac{C_{0.7R} (V_A^2 + (0.7\pi nD^2)^2)^{1/2}}{\nu}$$

2.2 Definition of Variables

Propeller thrust	(N)	T
Duct thrust	(N)	T_D
Ducted propeller thrust	(N)	T_P
Total thrust of a ducted propeller unit	(N)	T_T
Propeller torque	(Nm)	Q
Rate of revolutions of the model propeller	(rps)	n
Speed of advance of the model propeller	(m/s)	V_A
Chord length at $0.7R$	(m)	$C_{0.7R}$
Propeller diameter	(m)	D
Propeller radius	(m)	R
Mass density of water	(kg/m ³)	ρ
Kinematic viscosity	(m ² /s)	ν

3 PROCEDURE

3.1 Model and Installation

3.1.1 Model

The model propeller should be manufactured in accordance with Standard Procedure 7.5-01-01-01, Ship Models.

	ITTC – Recommended Procedures	7.5-02 -03-02.1 Page 3 of 9	
	Testing and Extrapolation Methods Propulsion, Propulsor Open Water Test	Effective Date 2002	Revision 01

The fairings forward and aft of a conventional pushing propeller should be modelled according to Fig.1.

For a pulling propeller, the nose cone should be modelled accordingly.

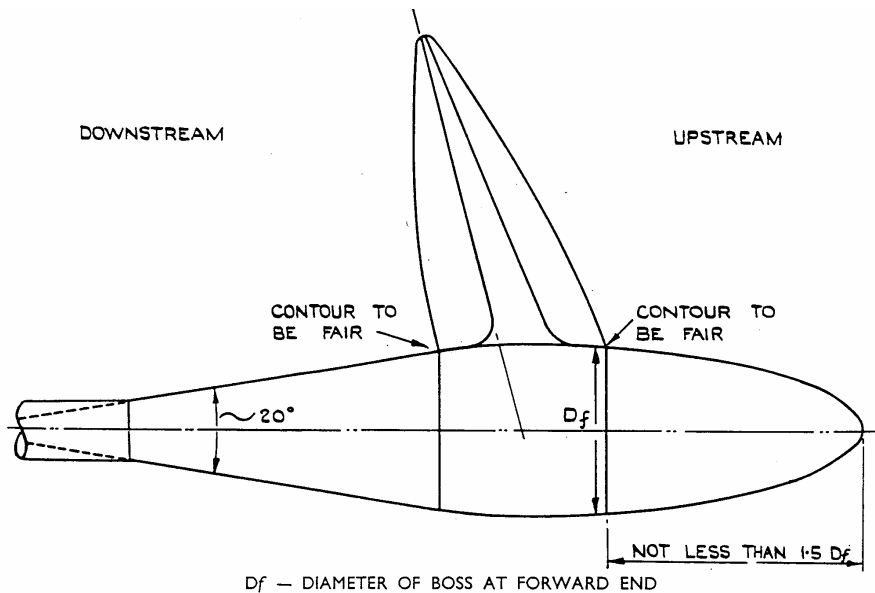

Figure 1 Geometry of Model Fairings

3.1.2 Installation

3.4.1.1. Conventional Propellers

The propeller model is to be mounted on a drive shaft. A streamlined nose cap of sufficient length to ensure that the inflow over the propeller hub is parallel to the shaft should be mounted upstream of the propeller model, Fig.1. In the case of a pulling propeller, the nose cone should be modelled according to the actual propeller geometry. The connection between the cap and the hub should be smooth

and without a gap. The size and shape of the nose cap should be recorded.

In order to eliminate a pressure build-up at the downstream end of the hub and the fixed shaft housing, the rotating part of the hub should be positioned in such a way to avoid any kind of pressure build-up. The arrangement used should be recorded and included in the test report.

The drive shaft housing should not be too close to the model propeller blades. A distance

of not less than $1.5 D$ to $2.0 D$ is recommended, where D is the propeller diameter. The drive shaft should be arranged parallel to the calm water surface and the carriage rails. A typical set up is shown in Fig. 2.

The propeller immersion has to be selected such that air drawing from the water surface is avoided at any test condition. As a guideline, an immersion of the propeller shaft of at least $1.5 D$ is recommended, where D is the diameter of the propeller. The immersion of the shaft centre line should be recorded and included in the test report.

When a current meter is used to measure the speed of advance of the propeller model, the immersion of the current meter should correspond to the immersion of the propeller shaft. The distance between the propeller and the current meter should be selected to ensure that the propeller model is not influenced by the current meter. A distance between the current meter and propeller model of at least $10 D$ is recommended, where D is the diameter of the model propeller.

The dimensions of the tank should be large enough to avoid blockage and should be included in the test report.

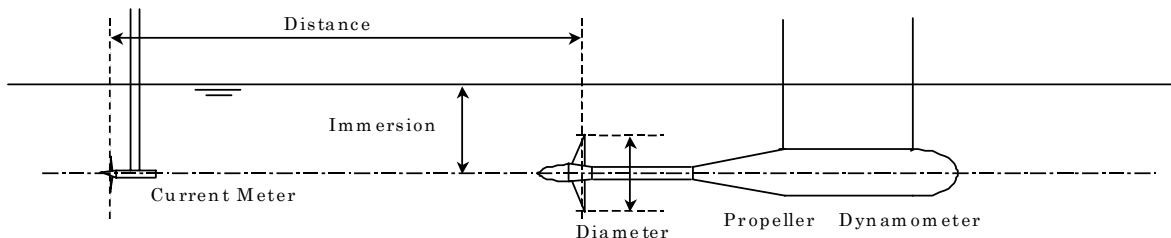

Figure 2 Typical Set Up for Tests on Conventional Propellers

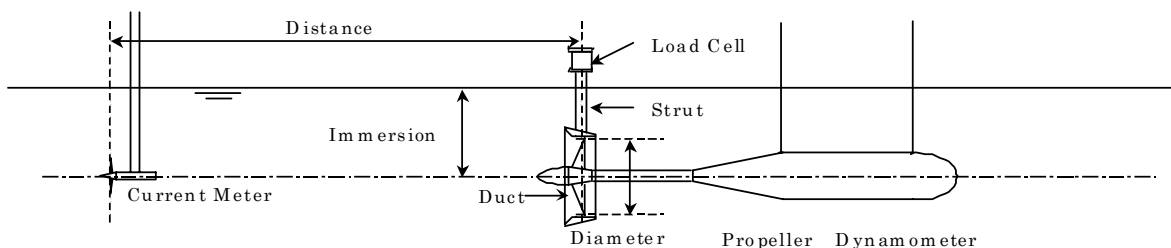



Figure 3 Typical Set Up for Tests on Ducted Propellers

	ITTC – Recommended Procedures	7.5-02 -03-02.1 Page 5 of 9	
	Testing and Extrapolation Methods Propulsion, Propulsor Open Water Test	Effective Date 2002	Revision 01

3.4.1.2. Ducted Propellers

The clearance between the propeller tips and the inner surface of the duct should be kept at the recommended design value. Depending on model scale, this value sometimes cannot be achieved. Then, a maximum of 1.0 mm clearance for a scaled model propeller of about 250mm diameter is considered to be satisfactory. The relative longitudinal position of the propeller and the duct should be adjusted to the design value.

The duct is usually supported by a strut which has a streamlined section shape. Only

the force acting on the duct should be measured during the test. A typical set up is shown in Fig.3.

The duct thrust is usually measured by a load cell with a shielded strut, or a strain gauge positioned between the duct and the strut. Another method is to measure the drag force acting on the strut separately as a function of advance velocity.

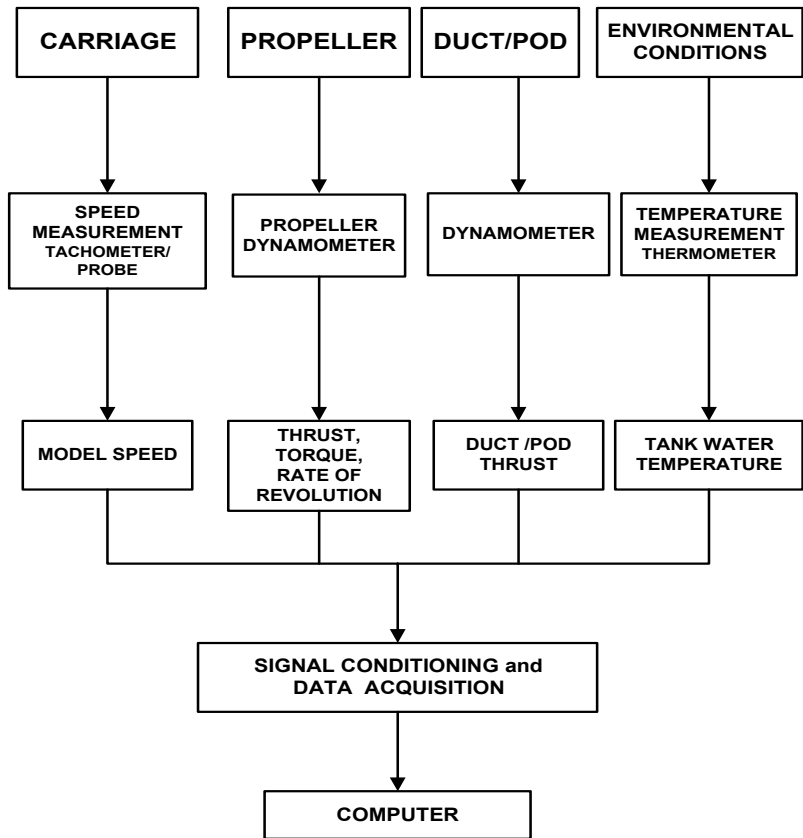



Figure 4 Typical Measurement System

	ITTC – Recommended Procedures	7.5-02 -03-02.1 Page 6 of 9	
	Testing and Extrapolation Methods Propulsion, Propulsor Open Water Test	Effective Date 2002	Revision 01

3.2 Measurement Systems

Fig 4. shows a typical measuring system:

The following quantities are measured:

- Model speed
- Propeller thrust
- Propeller torque
- Propeller rate of revolution
- Duct thrust (if fitted)
- Water temperature (for calculation of viscosity)

3.3 Instrumentation

3.3.1. General remarks

The performance of a propeller open water test requires the use of a propeller open water dynamometer which enables the measurement of thrust, torque and rate of revolution of the propeller. The quoted bias accuracies are for indicative purposes only. Uncertainty analysis should be used to derive the actual requirements.

3.3.2. Thrust

The propeller thrust is measured using the propeller open water dynamometer. In the case when the propeller is working in a nozzle, the additional thrust or the resistance of the nozzle has to be considered.

The thrust dynamometer should measure the thrust to within 0.2% of the maximum capacity of the dynamometer. This does not necessarily

imply that the thrust itself is measured to within the same tolerance of its true value.

3.3.3. Torque

The propeller torque is measured using the propeller open water dynamometer. In the torque measurement, it is essential to keep the shaft friction losses as low as possible.

The torque dynamometer should measure the torque to within 0.2% of the maximum capacity of the dynamometer. This does not necessarily imply that the torque itself is measured to within the same tolerance of its true value.

3.3.4. Rate of revolution

The rate of revolution of the propeller should be constant throughout the test run. Steadiness of the rate of revolution is essential in achieving reliable results.

The measurement instrumentation should measure the rate of revolution to within 0.2% of the maximum rate of revolution. This does not necessarily imply that the rate of revolution itself is measured to within the same tolerance of its true value.

The measurement instrumentation should measure the rate of revolution to within 0.2% of the maximum rate of revolution. This does not necessarily imply that the rate of revolution itself is measured to within the same tolerance of its true value.

	ITTC – Recommended Procedures	7.5-02 -03-02.1 Page 7 of 9	
	Testing and Extrapolation Methods Propulsion, Propulsor Open Water Test	Effective Date 2002	Revision 01

3.3.5. Speed

The speed of the propeller model should be measured to within 0.1% of the maximum carriage speed or within 3 mm/sec, whichever is the larger.

3.3.6. Temperature

The water temperature should be measured at the propeller shaft level using a thermometer.

3.4. Calibrations

3.4.2. General remarks

All devices used for data acquisition should be calibrated regularly. For calibration, the measured quantities should be either substituted by calibrated weights and pulses or checked by other measuring devices which have already been calibrated. Calibration diagrams, where the measured quantities (output values) are plotted against the calibration units (input units), may be useful to check the calibration itself, as well as the linearity of strain gauge or inductive instruments. Calibration should generally be in accordance with ITTC Quality Manual, Recommended Procedure 7.6-01-01.

Calibrations should preferably include as much of the measurement chain as possible (amplifier, filter, A/D converter). If the check indicates that the required accuracies cannot be met, the calibration should be renewed or the instrument replaced and the check repeated.

Daily checking of a pulse counter for speed measurements is usually not required. Instead, the check on this device is covered by calibrations carried out at regular intervals.

3.4.3. Propeller dynamometer:

3.4.3.1. Propeller Thrust

The calibration of the propeller open water dynamometer in respect of the propeller thrust should be carried out statically and, if possible, dynamically with calibrated weights. The dynamic calibration should be carried out at various rates of revolution.

3.4.2.2 Propeller Torque

The calibration of the propeller open water dynamometer in respect of the propeller torque should be carried out statically and, if possible, dynamically. For the static calibration, calibrated weights are applied to a lever of known length to simulate a moment on the dynamometer shaft. The dynamic calibration should be carried out, for example, by use of an eddy current brake

3.4.4. Rate of revolution

The calibration of the respective devices should be carried out by use of precise motor speed transmitters.

3.4.5. Speed

The calibration of the carriage speed will depend mainly on how the speed is measured in each tank. The carriage speed should be

	ITTC – Recommended Procedures	7.5-02 -03-02.1 Page 8 of 9	
	Testing and Extrapolation Methods Propulsion, Propulsor Open Water Test	Effective Date 2002	Revision 01

checked regularly and respective records should be stored.

3.4.6. Thermometer

Thermometers should be calibrated according to common standards and/or following the advice of the manufacturer.

3.5. Test Procedure and Data Acquisition

Prior to the tests, runs should be made to measure the influence of the streamlined nose cap. These measurements should be carried out with a propeller hub without blades, having the same shape as the real propeller hub. This hub should have the same weight as the propeller. Before and after each test series, the zero reference values of thrust and torque are determined. Zeros should be checked between runs to ensure no drift has occurred. The range of measurements should cover that of the open water tests in terms of rotational speed and speed of advance. The way these measurements are carried out, and the results, should be recorded.

In the case of tractoring propellers (where the propeller is ahead of a bossing) the influence of the propeller cap on the thrust and torque of the propeller is not relevant, as the propeller is tested in the same configuration as that used behind the ship.

During each open water test run, the values of thrust, torque, rate of revolution and speed of advance are recorded simultaneously. When the propeller works in a nozzle, or is designed to be used on pods or conventional Z-drives,

the forces of such devices in the direction of the propeller shaft should also be measured.

The range of advance coefficients should cover the range from $J = 0$ until $K_T < 0$, in order to determine accurately the point at which $K_T = 0$.

There should be sufficient waiting time between consecutive runs in order to achieve similar conditions and to obtain consistent results. This waiting time will depend on the size and type of model, model speed and test facility. The waiting times should be recorded.

The propeller open water tests should be conducted at least at two Reynolds Numbers; one should be at the Reynolds Number used for the evaluation of the propulsion test and the other should be as high as possible.

3.6. Data Reduction and Analysis

The model data derived from the experiment, namely thrust, torque and rate of revolution, should be plotted against the speed of advance. The measured thrust and torque are to be corrected for the effect of the streamlined nose cap, as determined before and/or after the actual open water test. The respective curves should be faired and the model values corresponding to required speeds of advance should be taken from the diagram.

The measured duct force (resistance or thrust) should be corrected for the effect of the (streamlined) support strut, as determined before or after the actual open water test.

	ITTC – Recommended Procedures	7.5-02 -03-02.1 Page 9 of 9	
	Testing and Extrapolation Methods Propulsion, Propulsor Open Water Test	Effective Date 2002	Revision 01

Values of water density and viscosity should be determined according to ITTC Recommended Procedure 7.5-02-01-03.

The required values of K_T , (K_{TD}), K_Q , η_0 and J are calculated according to the data reduction equations given in Section 2.1.

3.7. Documentation

The results from the test should be collated in a report which should contain at least the following information:

- Model Propeller Specification:
 - Identification (model number or similar)
 - Model scale
 - Main dimensions and particulars (see recommendations of ITTC Recommended Procedure 7.5-01-01-01 Ship Models)
 - Immersion of centreline of propeller shaft
- Particulars of the towing tank, including length, breadth and water depth
- Test date
- Parametric data for the test:
 - Water temperature
 - Water density
 - Kinematic viscosity of the water
 - Reynolds Number (based on propeller blade chord at $0.7R$)
- For each speed the following data should be given as a minimum:
 - Thrust and torque of the propeller

Rate of revolution

Force of nozzle in the direction of the propeller shaft

4 VALIDATION

4.1 Uncertainty Analysis

Uncertainty analysis should be performed in accordance with Uncertainty Analysis in EFD, Uncertainty Assessment Methodology as described in QM 7.5-02-01-01 and Uncertainty Analysis in EFD, Guidelines for Uncertainty Assessment as described in QM 7.5-02-01-02. In addition to the above, an example Uncertainty Analysis Example for Propeller Open Water Test is provided in  7.5-02-03-2.2.

4.2 Benchmark Tests

Benchmark data are collected and described in 'Benchmark Database for CFD, Validation for Resistance and Propulsion, QM 7.5-03-02-02

5 REFERENCES

- (1) ITTC 1999, Propulsion, Propulsor Open Water Test, 22nd International Towing Tank Conference, Seoul/Shanghai, Quality Manual, Procedure 4.9-03-03-02, Revision 00.